

HARPER HANDTRUCK MODEL - PGCSK19BLKO INSTRUCTIONS

PARTS LISTING

	QTY	PART NUMBER	DESCRIPTION
A	3	PGBLK-5	CROSSMEMBER
B	2	PGBLK-2	SIDE FRAME
D	4	HDW SC 3/8X1.5H	BOLT
E	4	HDW N MA15-15	NUT
F	1	PCSBLK	HANDLE
G	4	HDW SC 1/4X2 PH	BOLT
H	4	HDW N 82-15	NUT

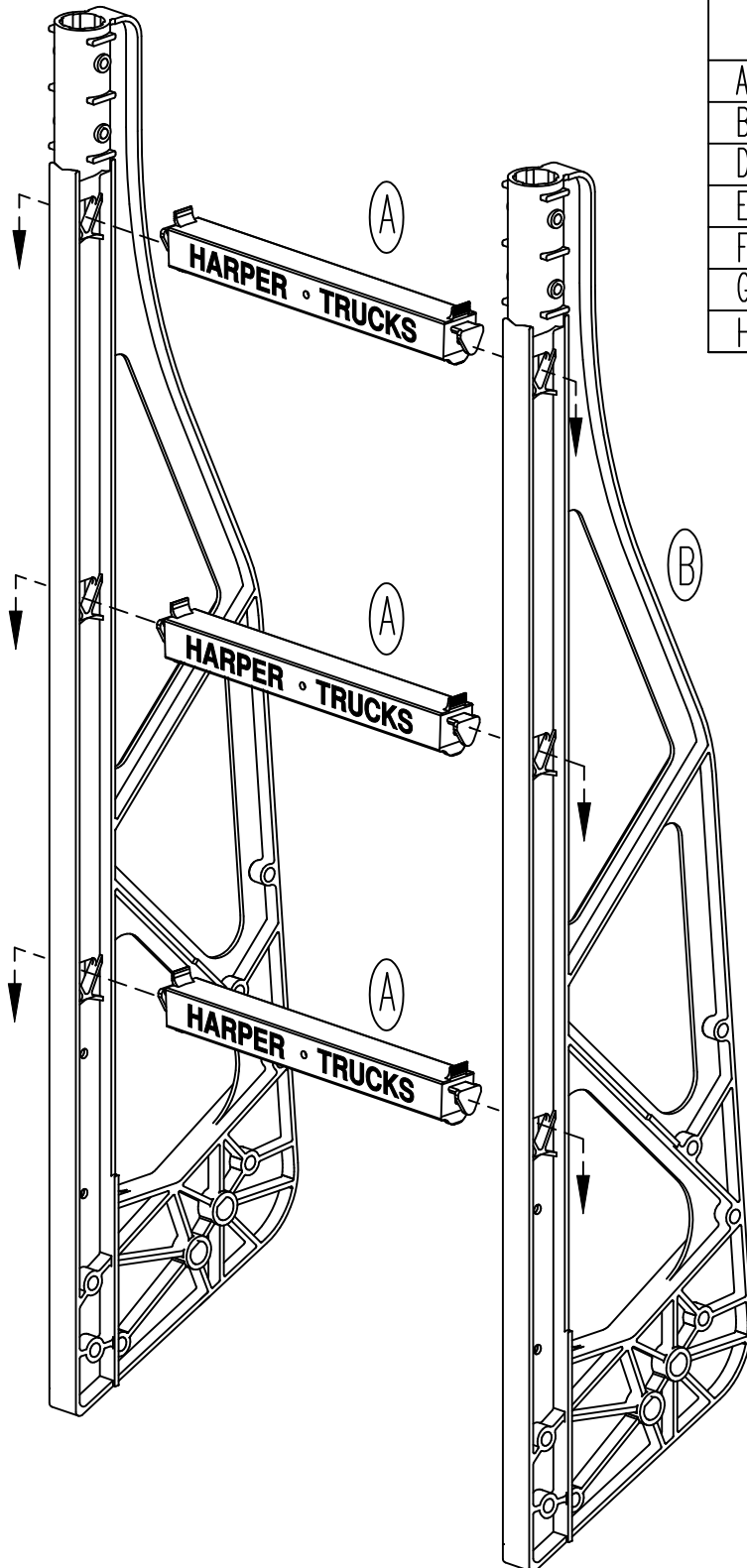

FRAME ASSEMBLY

1. INSERT CROSSMEMBERS (A), WITH NAME FORWARD, INTO THE SIDEFRAME (B). TAP DOWNWARD LIGHTLY TO SECURE TABS.

HANDLE ASSEMBLY

1. INSERT THE HANDLE (F) INTO THE SIDE-FRAME (B) SOCKET AND SECURE WITH FASTENERS (G&H).

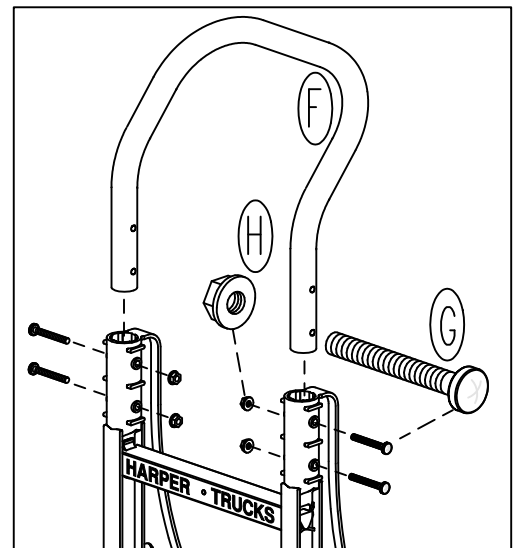

PARTS LISTING

	QTY	PART NUMBER	DESCRIPTION
I	1	PBSABLK-1	BASE PLATE
L	1	AX N225	AXLE
M	2	WH K16	WHEEL
N	8	HDW BU #2	WASHER
P	4	HDW P 106-12	COTTER PIN

BASE/AXLE ASSEMBLY

1. FASTEN THE BASE PLATE (I) TO THE FRAME WITH 4 BOLTS (D) AND NUTS (E).
2. SLIDE AXLE (L) THROUGH SIDEFRAME (B) AXLE HOLE AS SHOWN. INSERT 2 WASHERS (N) ON THE AXLE BETWEEN THE FRAMES.
3. INSTALL 2 COTTER PINS (P) IN THE AXLE BETWEEN THE SIDEFRAMES WITH THE WASHER BETWEEN THE COTTER PIN AND SIDEFRAME.
4. ASSEMBLE THE WHEELS ONTO THE AXLE WITH 2 WASHERS (N) ON THE INSIDE AND 1 WASHER (N) ON THE OUTSIDE OF THE WHEEL. SECURE WITH A COTTER PIN (P) THROUGH EACH END OF THE AXLE (L).

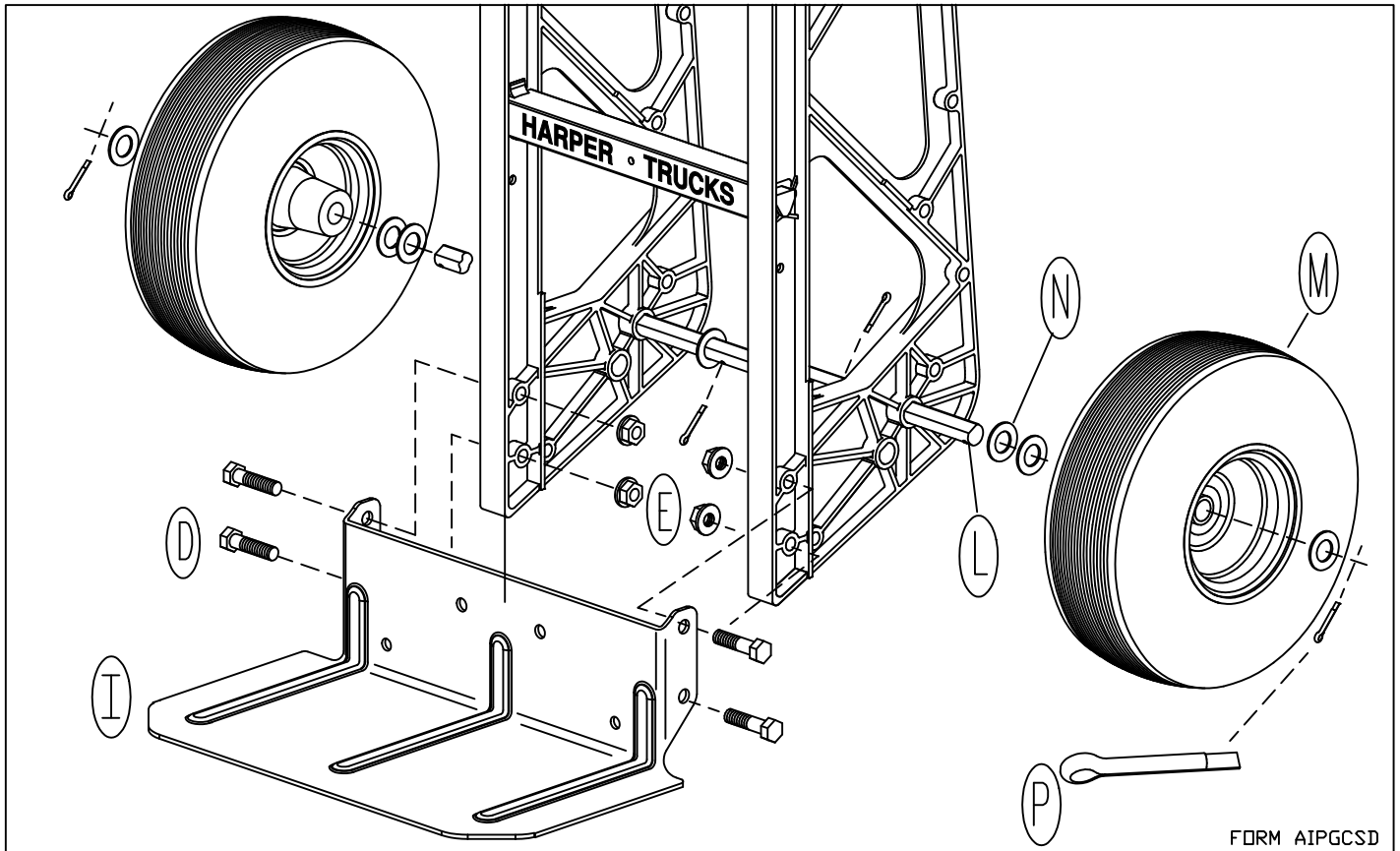

FORM AIPGCSD